



**Engineering**

**Technical Standard**

# **TS 0302 Stand-alone Solar Power Supply Systems**

**Version:** 1.0

**Date:** 30 June 2018

**Status:** FINAL

**Document ID:** SAWS-ENG-0302

© 2018 SA Water Corporation. All rights reserved. This document may contain confidential information of SA Water Corporation. Disclosure or dissemination to unauthorised individuals is strictly prohibited. Uncontrolled when printed or downloaded.



## Copyright

This Technical Standard remains intellectual property of the South Australian Water Corporation. It is copyright and all rights are reserved by SA Water. No part may be reproduced, copied or transmitted in any form or by any means without the express written permission of SA Water.

The information contained in this Standard is strictly for the private use of the intended recipient in relation to works or projects of SA Water.

This Standard has been prepared for SA Water's own internal use and SA Water makes no representation as to the quality, accuracy or suitability of the information for any other purpose.

## Application and Interpretation of this Document

It is the responsibility of the users of this Standard to ensure that the application of information is appropriate and that any designs based on this Standard are fit for SA Water's purposes and comply with all relevant Australian Standards, Acts and regulations.

Users of this Standard accept sole responsibility for interpretation and use of the information contained in this Standard. Users should independently verify the accuracy, fitness for purpose and application of information contained in this Standard.

Only the current revision of this Standard should be used which is available for download from the SA Water website.

## Significant/Major Changes Incorporated in This Edition

Document number changed from TS 80 to TS 0302. Title changed from 'Solar Power Systems'.

Technical changes described in this clause are related to TS 80 revision 1.0, dated 29 March 2016. Clause numbers described below relate to the superseded document.

General

Replaced "a.c." and "d.c." with "AC" and "DC"

Clause 1.3

Review and update all standards

Clause 4.1

Clause reviewed and updated to be in line with TS300 ambient conditions.

Clause 4.2.3

Clause reviewed and updated to allow for pole options to be either Tilt or Fixed.

Clause 4.4.9

Item 3 reviewed and removed requirement

Clause 5.6

Existing text from clause 5.6 separated into clauses 5.6.1 and 5.6.2

Clause 5.4.1

Item 2 reviewed and removed requirement

Appendix A2

Added typical Fixed Pole installation

Appendix B2

Updated typical equipment data

Added pole option (Tilt / Fixed)



## Document Controls

### Revision History

Revision	Date	Author	Comments
V1	4 August 2008	Manager of Engineering	
1.0	29 March 2016	T Zelipski	
0.1	15 May 2017	Anthony Mew	Review and update to new document, previously TS 80
1.0	30 June 2018	Justin Hamra	New document TS 0302

Template: Technical Standard Version 6.00, 10/05/2016

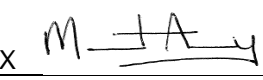
### Approvers

Role	Signature and Date
Principal Electrical Engineer Justin Hamra	27/06/2018  X  _____ Signer's Name Signed by: HA003627
Manager Engineering Technical Services Murat Aksoy	27/06/2018  X  _____ Signer's Name Signed by: AK003305
Senior Manager Engineering Services Richard Gray	27/06/2018  X  _____ Signer's Name Signed by: GR001964

### Reviewers

Role	Name	Revision	Review Date
Senior Electrical Engineer	Chris Harris	0.1	20/6/2017
Senior Electrical Engineer	Jonathan Nicholls	0.1	14/6/2017
Senior Electrical Engineer	Sachin Pandey	0.1	16/6/2017
Lead Asset Planner, M&E	Francis Fung	0.1	7/6/2017
Electrical Team Leader – Murray Bridge	Mark Asser	0.1	9/6/2017
Electrical Team Leader - Riverland	Darran Bright	0.1	16/6/2017
Electrical Team Leader – Crystal Brook	Tony Boylan	0.1	16/6/2017
Electrical Team Leader – South Para	Heath Bache	0.1	19/6/2017

## Contents

<b>1</b>	<b>Introduction</b> .....	<b>6</b>
1.1	Purpose .....	6
1.2	Acronyms and Abbreviations .....	6
1.3	Definitions .....	7
1.4	References .....	8
1.4.1	Australian and International Standards.....	8
1.4.2	SA Water Documents.....	8
<b>2</b>	<b>Scope</b> .....	<b>9</b>
2.1	Approval to Deviate From This Standard .....	9
2.2	Design Criteria.....	9
<b>3</b>	<b>General Arrangement</b> .....	<b>11</b>
<b>4</b>	<b>Solar Power Supply System Equipment</b> .....	<b>12</b>
4.1	Environmental Requirements.....	12
4.2	Array Support Structure .....	12
4.2.1	Concrete Footing .....	12
4.2.2	Pole Support Structure .....	12
4.2.3	Pole Tilt Mechanism .....	12
4.2.4	Antenna Support Bracket.....	12
4.3	Cubicles .....	13
4.3.1	General .....	13
4.3.2	Control Cubicle.....	13
4.3.3	Battery Cubicle .....	13
4.3.4	Lighting.....	13
4.4	Electrical Equipment .....	13
4.4.1	General .....	13
4.4.2	Electrical Capacity.....	13
4.4.3	Photovoltaic Array.....	14
4.4.4	Regulator .....	14
4.4.5	Batteries .....	15
4.4.6	Converter.....	15
4.4.7	Inverter .....	15
4.4.8	Indications .....	16
4.4.9	Output Signals .....	16
<b>5</b>	<b>Installation</b> .....	<b>17</b>
5.1	General.....	17
5.2	Support Structure.....	17
5.3	Cubicles.....	17
5.4	Electrical Equipment .....	17
5.4.1	Photovoltaic Array.....	17
5.4.2	Battery Bank .....	17

5.4.3	Cabling .....	17
5.5	Labelling and Signs .....	17
5.6	Earthing and Lightning Protection .....	18
5.6.1	Earthing .....	18
5.6.2	Lightning Protection .....	18
<b>6</b>	<b>Inspection and Testing .....</b>	<b>19</b>
6.1	Inspection and Testing.....	19
<b>7</b>	<b>Technical Information to be Provided.....</b>	<b>20</b>
7.1	Design .....	20
7.2	Operation and Maintenance Manual .....	20
<b>Appendix A</b>	<b>- Typical Drawings .....</b>	<b>21</b>
A1	Typical Electrical Schematic.....	21
A2	Typical Installation .....	22
<b>Appendix B</b>	<b>- Site Schedules .....</b>	<b>24</b>
B1	Stand-alone Solar Power Supply System Site Schedule .....	24
B2	Example Schedule .....	25

### List of figures

Figure 1 – Typical Electrical Schematic .....	21
Figure 2 – Typical Tilt Pole Solar Installation .....	22

### List of tables

Table 1 - Table of Definitions Used in this Technical Standard .....	7
Table 2 – Standards Referred to in this Technical Standard .....	8
Table 3 –Referenced Internal Standards.....	8

# 1 Introduction

SA Water is responsible for operation and maintenance of an extensive amount of engineering infrastructure.

This standard has been developed to assist in the design, maintenance, construction, and management of this infrastructure.

## 1.1 Purpose

The purpose of this standard is to detail minimum requirements to ensure that assets covered by the scope of this standard are constructed and maintained to consistent standards and attain the required asset life.

## 1.2 Acronyms and Abbreviations

The following acronyms and abbreviations are used in this document:

Term	Description
<b>AS</b>	Australian Standards
<b>LV</b>	Low Voltage: Exceeding extra-low voltage, but not exceeding 1,000 V a.c. or 1,500 V d.c.
<b>LED</b>	Light Emitting Diode
<b>MPPT</b>	Maximum Power Point Tracking
<b>Must</b>	Indicates a statement is mandatory
<b>PV</b>	Photovoltaic
<b>RTU</b>	Remote Telemetry Unit
<b>SA Water</b>	South Australian Water Corporation
<b>SCADA</b>	Supervisory Control and Data Acquisition
<b>Shall</b>	Indicates a statement is mandatory
<b>Should</b>	Indicates a recommendation
<b>TS</b>	SA Water Technical Standard

## 1.3 Definitions

The following definitions are applicable to this document:

**Table 1 - Table of Definitions Used in this Technical Standard**

Term	Description
Contractor	A person or firm that undertakes a contract to provide materials or labour to perform a service or do a job.
Corrosive Environments	<p>Any environment where there is a presence of destructive chemicals in which the electrical assets are subject to deleterious effects. Examples of destructive chemicals are:</p> <p>Hydrogen Sulfide; Ammonia; Chlorine; Sodium Chloride; etc.</p> <p>Any installation located close (within 1 km of the ocean) or in high ground water environments (exhibiting salinity) should be considered as a corrosive environment for the purposes of this Technical Standard.</p>
SA Water's Representative	<p>The SA Water nominated representative with delegated authority under a Contract or engagement, including (as applicable):</p> <ul style="list-style-type: none"> <li>• Superintendent's Representative (per AS 4300 and AS 2124, etc.)</li> <li>• SA Water Project Manager</li> <li>• SA Water nominated contact person</li> </ul>
Site Schedule	The schedule of information that should be completed at the project definition phase. This information should be passed to the designer/installer for them to complete their design of the required Stand-alone Solar Power Supply System. <a href="#">Appendix B</a> lists a template and example.
Standard	Reference to a SA Water Technical Standard.
Switchboard	An assembly of circuit protective devices, with or without switchgear, instruments or connecting devices, suitably arranged and mounted for distribution to, and protection of, one or more submains or final subcircuits or a combination of both.
Voltage	<p>(a) Extra-low voltage: Not exceeding 50 V a.c. or 120 V ripple-free d.c.</p> <p>(b) Low voltage: Exceeding extra-low voltage, but not exceeding 1,000 V a.c. or 1,500 V d.c.</p> <p>(c) High voltage: Exceeding low voltage.</p>

## 1.4 References

### 1.4.1 Australian and International Standards

Any Standard referred to in this Specification shall be of the latest edition (including amendments) of that Standard at the date of calling of tenders.

The following table identifies Australian and International standards and other similar documents referenced in this document:

**Table 2 – Standards Referred to in this Technical Standard**

Number	Title
<b>AS/NZS 1664</b>	Aluminium structures
<b>AS/NZS 1170</b>	Structural design actions (Series)
<b>AS/NZS 1768</b>	Lightning Protection
<b>AS/NZS 3000</b>	Wiring Rules
<b>AS 3600</b>	Concrete structures
<b>AS 4086.1</b>	Secondary batteries for use with stand-alone power systems - General Requirements
<b>AS 4086.2</b>	Secondary batteries for use with stand-alone power systems - Installation and maintenance
<b>AS 4100</b>	Steel structures
<b>AS/NZS 4509.1</b>	Stand-alone power systems - Safety and installation
<b>AS/NZS 4509.2</b>	Stand-alone power systems - System design
<b>AS/NZS 5033</b>	Installation and safety requirements for photovoltaic (PV) arrays
<b>AS/NZS 5603</b>	Stand-alone inverters – Performance requirements
<b>AS 60529</b>	Degrees of protection provided by enclosures (IP Code)

### 1.4.2 SA Water Documents

#### 1.4.2.1 Standard Documents

The following table identifies the SA Water standards and other similar documents referenced in this document:

**Table 3 –Referenced Internal Standards**

Number	Title
TS 0132	Operating and Maintenance Manuals
TS 0300	Supply and Installation of Low Voltage Electrical Equipment



## 2 Scope

This Technical Standard Specification covers the design, supply and installation of stand-alone solar power supply systems for low and extra low voltage equipment.

This Technical Standard Specification shall be read in conjunction with the associated project specification, drawings and any documents annexed to the project specification. The provisions of this Technical Standard Specification shall apply unless they are specifically deleted or amended in the project specification or drawings which shall then take precedence. The currency of these Standards should be checked prior to use.

### 2.1 Approval to Deviate From This Standard

Approval may ultimately be granted by the SA Water Principal Electrical Engineer, to deviate from the requirements as stipulated in this Standard, if the functional requirements (e.g. asset life, ease of use, maintainability, etc.) for the asset differs from those stated in the Standard, but is assessed as still being acceptable. Any approval to deviate from the stated requirements of this Standard shall not be seen as creating a precedent for future like projects. Any request to deviate from this Standard must be carried out on a project by project basis, where each alternative proposal will be individually assessed on its own merit. No action should be taken until a written reply to such a request has been received.

SA Water encourages and welcomes suggestions as to the improvement of this standard for future releases. These suggestions should be passed through to the SA Water Principal Electrical Engineer.

### 2.2 Design Criteria

The design criteria must be ascertained and agreed with SA Water or its representative during all stages of investigation, concept design and detailed design in order to achieve a value-for-money installation that is fit for purpose and with minimum or negligible risks to SA Water. The design criteria should consider the following aspects:

#### 1. Life Cycle Costs

Designs should be innovative and incorporate the appropriate techniques and technology, in conjunction with the selection of appropriate equipment, to minimize the life cycle costs, while satisfying operation and maintenance requirements. Energy consumption must be given particular attention in this respect.

#### 2. Security of Operation

Designs should take into account the failure of a single item of equipment or a fault in a particular area of an installation is confined to the associated part of the installation and does not affect the continuous operation of the remaining parts of the installation, where possible.

#### 3. Reliability

The installations are to be designed to minimize the likelihood of a failure, taking into consideration the electricity supply characteristics, ambient conditions, load characteristics and operation and maintenance requirements.

#### 4. Upgradability

The installations are to be designed to facilitate future upgrades where applicable.

#### 5. Interchangeability

The installations are to be designed to maximize the interchangeability of components and assemblies as far as practical to improve flexibility and reduce the spare parts inventory.

6. Operation, Maintenance and Fault-Finding Facilities

The installations are to be provided with suitable and adequate facilities to allow ease of operation, maintenance and fault finding.

7. Environmental Considerations

The installations are to be designed and suitable equipment selected to avoid or minimize unacceptable impact on the environment as far as possible.

8. Safety Considerations

The installations are to be designed with the safety and welfare of construction, operation and maintenance personnel and the general public in mind, complying with statutory regulations. Wherever possible, electrical equipment and wiring should not be located in areas classified as hazardous.

### 3 General Arrangement

A stand-alone solar power supply system shall consist of the following unless otherwise specified in the project Site Schedule (refer to 7.2Appendix B):

1. Concrete footing,
2. Pole support structure mounted on the concrete footing,
3. Photovoltaic array mounted at the top of the pole support structure,
4. Control cubicle integrated or attached to the pole support structure (unless specified otherwise by the Site Schedule) accommodating the associated electrical equipment,
5. Battery cubicle integrated or attached to the pole support structure (unless specified otherwise by the Site Schedule) accommodating the batteries,

shield, as necessary (unless cubicles located indoors),

6. If specified, a support bracket for the mounting of a radio antenna(s).

## 4 Solar Power Supply System Equipment

### 4.1 Environmental Requirements

Equipment shall be rated for operation in the following ambient temperature range:

Outdoors: -5 °C to 50 °C

Indoors: 0 °C to 40 °C

### 4.2 Array Support Structure

#### 4.2.1 Concrete Footing

A concrete footing shall support the pole support structure and shall be designed to take into account the appropriate terrain category (for wind loading) and foundation (geotechnical) conditions at the site in accordance with AS 3600 and AS/NZS 1170.

#### 4.2.2 Pole Support Structure

The pole structure shall be designed in accordance with AS/NZS 4509.1, AS/NZS 1170.2, and the following:

1. The pole structure height shall be a minimum of 5 m, to allow for PV array and 1m clearance to optional antenna support bracket below, to minimise the possibility of vandalism,
2. The pole structure shall be designed and fabricated from hot dipped galvanised steel in accordance with AS 4100, or aluminium in accordance with AS/NZS 1664,
3. The pole structure shall be capable of supporting the weight and wind loading forces of the photovoltaic array mounted at the top of the pole and cubicles attached to the bottom of the pole,
4. The photovoltaic array shall be fixed to the structure with a mechanism to adjust the tilt angle for seasonal variations, if required (Refer to AS/NZS 4509.1 Clause 3.1.5) and the angular direction. The photovoltaic modules shall be mounted in such a way as to minimise the potential for theft or vandalism.

#### 4.2.3 Pole Tilt Mechanism

Unless a fixed pole installation (typical installation shown in Appendix A2 Figure 3) has been specified in the Site Schedule, the pole shall have the ability to be tilted down above the cubicles to facilitate maintenance of equipment at the top of the pole. The tilting shall be by means of a central pivot as shown in the typical installation in Appendix A2 Figure 2. Equipment to provide lowering and raising of the pole (e.g. rope and pulley) shall form an integral part of the pole support structure. A means of fixing the pole at any angle while lowering, shall be provided. Access to this facility shall be restricted to prevent vandals from damaging equipment.

The pole shall be provided with a weight fixed at the bottom when required to counterbalance the weight of the solar panels so that the weight imbalance is between 5 kg and 10 kg heavier at the top of the pole.

#### 4.2.4 Antenna Support Bracket

Where required by the Site Schedule, the pole structure shall be provided with a support bracket mounted at the top of the pole for others to install a radio antenna(s) and feeder cable(s).

The bracket shall be made of hot dipped galvanised steel in accordance with AS 4100 or aluminium in accordance with AS/NZS 1664 and shall be of a length sufficient to clear the PV panel in any direction by a minimum of 250 mm. The bracket shall be capable of supporting a

load of 10 kg at the end, and sufficiently rigid to prevent distortion due to wind loading on the antenna(s). The bracket shall be set at a minimum of 4m high, and adjustable in height and rotation around the pole.

## 4.3 Cubicles

### 4.3.1 General

Cubicles shall be in accordance with TS 0300 and this clause.

#### 4.3.1.1 Indoor Cubicles

Indoor cubicles shall comply with the metal indoor cubicle requirements specified in TS 0300.

#### 4.3.1.2 Outdoor Cubicles and Weather Shield

Outdoor Cubicles shall comply with the metal outdoor cubicle requirements specified in TS 0300.

Outdoor cubicles shall be fitted with a weather shield to protect the cabinets from the direct rays of the sun and pooling of water. There shall be at least 50 mm clearance between the sides of the cubicles and the weather shield to allow for the installation of conduits.

Cubicles shall be designed to be vandal resistant in accordance with the metal vandal resistant cubicle requirements specified in TS 0300.

### 4.3.2 Control Cubicle

The control cubicle shall contain all the electrical equipment supplied under this specification with the exception of the battery bank. This includes regulators, converters, inverters, distribution boards, meters, lighting, protective equipment, terminal strips, conduits and cabling.

The cubicle shall have sufficient space as per the Site Schedule for the mounting of SA Water equipment, as required.

### 4.3.3 Battery Cubicle

The battery cubicle shall contain only the batteries for the battery bank and shall be in accordance with AS 4086.1, AS 4086.2, AS/NZS 4509.1 and AS/NZS 4509.2.

The battery cubicle shall have natural or forced ventilation. The method of ventilation and sizing of ventilation apertures shall meet the provisions of AS 4086.2.

### 4.3.4 Lighting

A low wattage (LED) light shall be provided for the inside of the electrical cubicle in accordance with TS 0300.

## 4.4 Electrical Equipment

### 4.4.1 General

All electrical equipment shall comply with TS 0300.

### 4.4.2 Electrical Capacity

The Contractor shall design and size the electrical capacity of the solar power supply system, including all components, for the specified loads. All electrical equipment shall be rated for a capacity increase of 60 % above the loads specified in the Site Schedule.

The battery cubicle shall be provided with sufficient spare space and facilities to add a minimum of 20 % more battery capacity, or an additional equally-dimensioned battery; whichever is greater.

### 4.4.3 Photovoltaic Array

The photovoltaic (PV) array for the renewable supply of power shall be designed in accordance with AS/NZS 4509.2, AS/NZS 5033, and the following sub causes.

#### 4.4.3.1 PV Modules

The PV modules used shall be in accordance with the following:

1. Nominal output voltage of 12 V DC or 24 V DC,
2. Efficiency energy conversion ratio greater than 17 % at the ambient temperatures specified in clause ,
3. Capable of operating at the installation location, considering ambient temperatures and extreme weather conditions (e.g. hail, snow, etc.),
4. Have a warranted power output of not less than 90 % of nominal, for a minimum of 10 years,
5. Bird deterrent devices shall be provided to stop birds resting on PV modules.

#### 4.4.3.2 PV Array

The PV array shall be in accordance with the following:

1. The PV modules used for the creation of the PV array shall all be of the same model, type and characteristics,
2. An equal number of PV modules shall be used within each parallel string,
3. Capable of supplying the required load (including the capacity increase of 20 %),
4. Sized to account for seasonal variations, and where necessary, for local geographic features at the site,
5. Sized to account for the regulator used in accordance with AS/NZS 4509.2,
6. Adequately de-rated considering component efficiencies, tolerances and system losses in accordance with AS/NZS 4509.2,
7. Provided with bypass diodes used in parallel with each module (preferably in parallel with each sub-section of module cells) to prevent the modules from becoming reversed-biased and causing photovoltaic hot spots. The bypass diodes used shall minimise any loss in efficiency of the modules and shall be rated in accordance with AS/NZS 5033 Clause 4.3.9.

### 4.4.4 Regulator

The regulator shall be in accordance with the following:

1. Maximum Power Point Tracking (MPPT) regulators shall be used. The power conversion efficiency shall be a minimum of 95 % and the PV array power shall not exceed the rated power of the MPPT,
2. Capable of supplying the required load (including the capacity increase of 20 %),
3. Capable of accepting the maximum voltage from the PV array,
4. Capable of controlling the battery charging and compatible with the chosen battery type,
5. Capable of staged battery charging (Boost, Absorption, Float, and Equalisation) and shall ensure that the battery does not become overcharged,

6. Capable of altering the maximum charge voltage to account for the temperature of the electrolyte,
7. Prevent reverse current from flowing from the batteries to the PV array, otherwise blocking diodes will be required in accordance with AS/NZS 5033 Clause 4.3.10.

## 4.4.5 Batteries

### 4.4.5.1 General

Batteries for the storage and supply of power shall be in accordance with AS/NZS 4509.2, AS 4086.1 and the following:

1. Suitable for photovoltaic applications,
2. Life expectancy of a minimum of 7 years,
3. Low Maintenance,
4. Heavy Duty Terminals,
5. Explosion resistant,
6. Self-discharge rate not greater than 0.5 – 1.0 % per week,
7. Operational at low internal pressures,
8. Capable of supplying the surge demand of the installation,
9. Compatible with the specified regulator,
10. Deep cycle capability.

### 4.4.5.2 Battery Bank

The battery bank shall comply with the following:

1. All batteries shall be of the same model type and characteristics,
2. The battery bank shall be sized to enable the solar power supply system to operate with no charging current from the PV array for a minimum of 5 days. Calculations shall be provided to SA Water for approval in determining the capacity of the battery bank. Geographical location should be considered to ensure that these requirements are met.

## 4.4.6 Converter

If a converter is required by the Site Schedule, then the converter shall comply with the following:

1. Capable of accepting an input voltage of 12 V DC and supplying an output voltage of 24 V DC,
2. Shall have conversion efficiency at full load of no less than 85 %,
3. Capable of supplying the required load current plus a future load capacity increase of 20 %.

## 4.4.7 Inverter

If an inverter is required by the Site schedule, then the inverter shall comply with AS/NZS 5603 and the following:

1. Capable of accepting a nominal input voltage of 12 V DC,
2. Capable of supplying a nominal output voltage of 230 V AC, 50 Hz,
3. Capable of supplying the required load current plus a future load capacity increase of 20 %.

## 4.4.8 Indications

Local indications shall be provided for the following parameters, as a minimum:

1. PV array voltage,
2. PV array current,
3. Regulator output voltage,
4. Regulator output current.

These indications shall preferably be provided by a display built into the regulator or by a suitable multi-function meter to be approved by SA Water's Representative.

## 4.4.9 Output Signals

The following signals shall be provided at a terminal strip within the control cubicle for input to equipment provided by SA Water:

1. Battery Voltage (analogue - actual voltage from a protected circuit),
2. Low Battery Voltage alarm (digital – voltage free contact rated at 12 V DC, 1 A which opens on low battery voltage).



## 5 Installation

### 5.1 General

All electrical work shall be in accordance with AS/NZS 3000, this Specification and TS 0300.

### 5.2 Support Structure

The location of the pole support structure shall be as approved by SA Water's Representative. Care shall be taken in locating the final position of the pole to avoid problems such as future shadows from growing trees.

The pole support structure shall be appropriately fixed to the concrete footing. The pole footing shall be designed taking into consideration all the forces on the structure in accordance with the relevant Australian Standards and the site soil conditions. The pole footing shall not be founded in fill material unless it is certified engineered fill.

### 5.3 Cubicles

The installation of cubicles shall be in accordance with the following:

1. The cubicles shall be installed in accordance with the typical installation shown in appendix A2 and as per the Site Schedule. (Either outdoors attached to the pole support structure or indoors in an approved location.),
2. For outdoor cubicle installations, a suitable air gap according to heat load calculations shall be provided between the rear of the cubicles and the weather shield, and there shall be at least 100 mm free space below the control cubicle to allow for installation of conduits. The bottom of the weather shield and the battery cubicle shall both be a minimum of 100 mm above the concrete base to facilitate the installation of conduits,
3. Where stainless steel cubicles are fixed to a hot-dipped galvanised or aluminium structure, then stainless steel bolts, nuts and washers shall be used, and plastic washers shall be used to prevent contact between the dissimilar materials, i.e. stainless steel and hot dipped galvanised or aluminium materials,
4. Signage shall be provided on the battery cubicle in accordance with AS 4086.2.

## 5.4 Electrical Equipment

### 5.4.1 Photovoltaic Array

The photovoltaic array shall be installed in accordance with AS/NZS 4509.1 and AS/NZS 5033, noting the following:

1. The array shall be positioned, orientated and installed to maximise power output whilst considering geographic features and the elimination of shading. Refer to AS/NZS 5033 Clause 2.1.10,
2. The array shall be mounted to avoid contact between dissimilar metals that could produce electrolysis, refer to AS/NZS 5033, Clause 2.2.7.

### 5.4.2 Battery Bank

The battery bank shall be installed in accordance with AS 4086.2, and AS/NZS 4509.1 Clause 7.

### 5.4.3 Cabling

All cables shall be supplied and installed in accordance with TS 0300.

## 5.5 Labelling and Signs

Labelling and signs shall be in accordance with AS 4509.1, AS/NZS 5033 and TS 0300.

## **5.6 Earthing and Lightning Protection**

### **5.6.1 Earthing**

The installation shall be earthed in accordance with AS/NZS 3000.

### **5.6.2 Lightning Protection**

A lightning protection risk assessment shall be conducted in accordance with AS/NZS 1768, and, if deemed required, the installation shall comply with AS/NZS 1768.

## 6 Inspection and Testing

### 6.1 Inspection and Testing

SA Water's Representative reserves the right to inspect the installation and shall be given ample notice of any testing to be carried out. Inspection and Testing shall be completed in accordance with the inspection and testing clauses of TS 0300, and the installation shall be tested in accordance with AS 4509.1, Clause 10 and AS/NZS 5033, Appendix D.

The results of all tests carried out on the electrical equipment shall be recorded on test sheets that have been approved by SA Water.

## 7 Technical Information to be Provided

### 7.1 Design

The Contractor shall provide the following information, as a minimum, prior to construction:

1. Details (datasheets) of all equipment offered (manufacturer, model, ratings, etc.),
2. Structural capability details of poles provided,
3. Details of the method of pole lowering/raising,
4. Details of the antenna support bracket (if specified),
5. Lightning risk assessment and protection study, if relevant,
6. Details of construction relating to vandal-proofing,
7. Calculations supporting the determination of panel array and battery bank sizing/capacity. This shall include an analysis of the proposed location, and the amount of "sun days" obtained from information obtained from the Bureau of Meteorology,
8. Cubicle heat loading calculations,
9. Details of how the battery temperature will be regulated,
10. Proposed inspection and test sheets.

### 7.2 Operation and Maintenance Manual

The Contractor shall provide an Operation and Maintenance Manual which complies with the requirements of TS 0132.

# Appendix A - Typical Drawings

## A1 Typical Electrical Schematic

Figure 1 – Typical Electrical Schematic

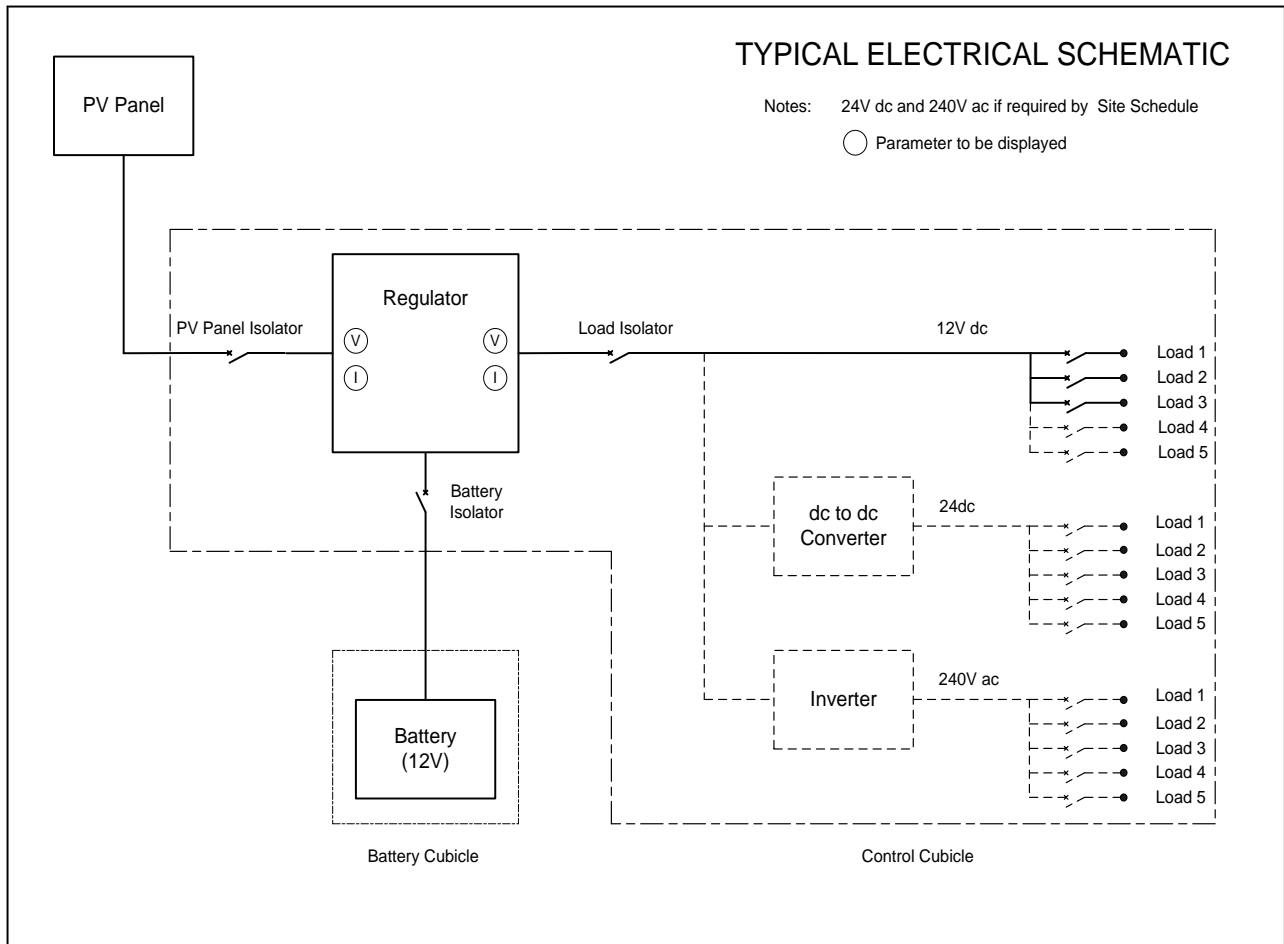

## A2 Typical Installation

Figure 2 – Typical Tilt Pole Solar Installation

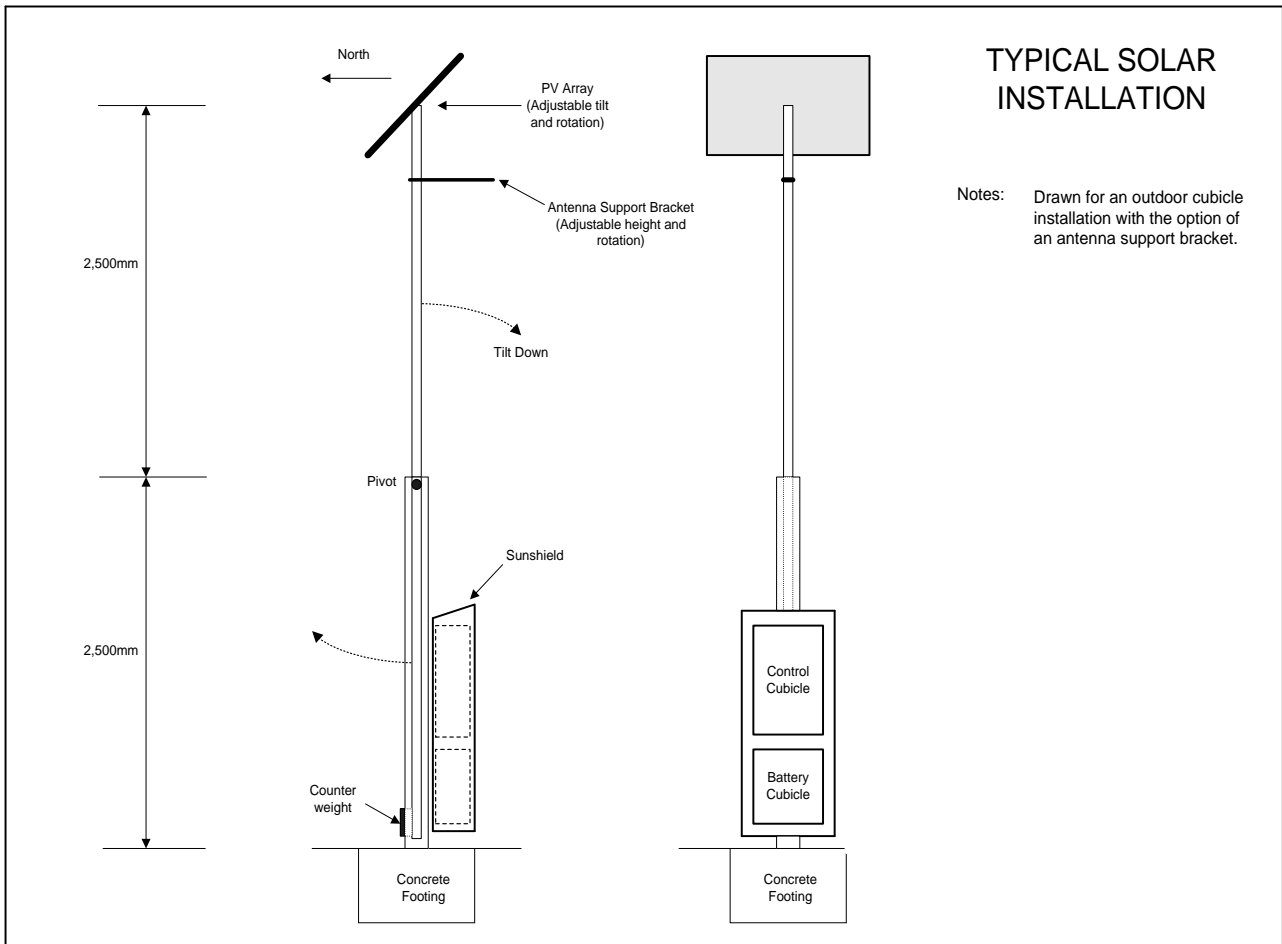

NB: Dimensions are typical, only.

**Figure 3 – Typical Fixed Pole Solar Installation**

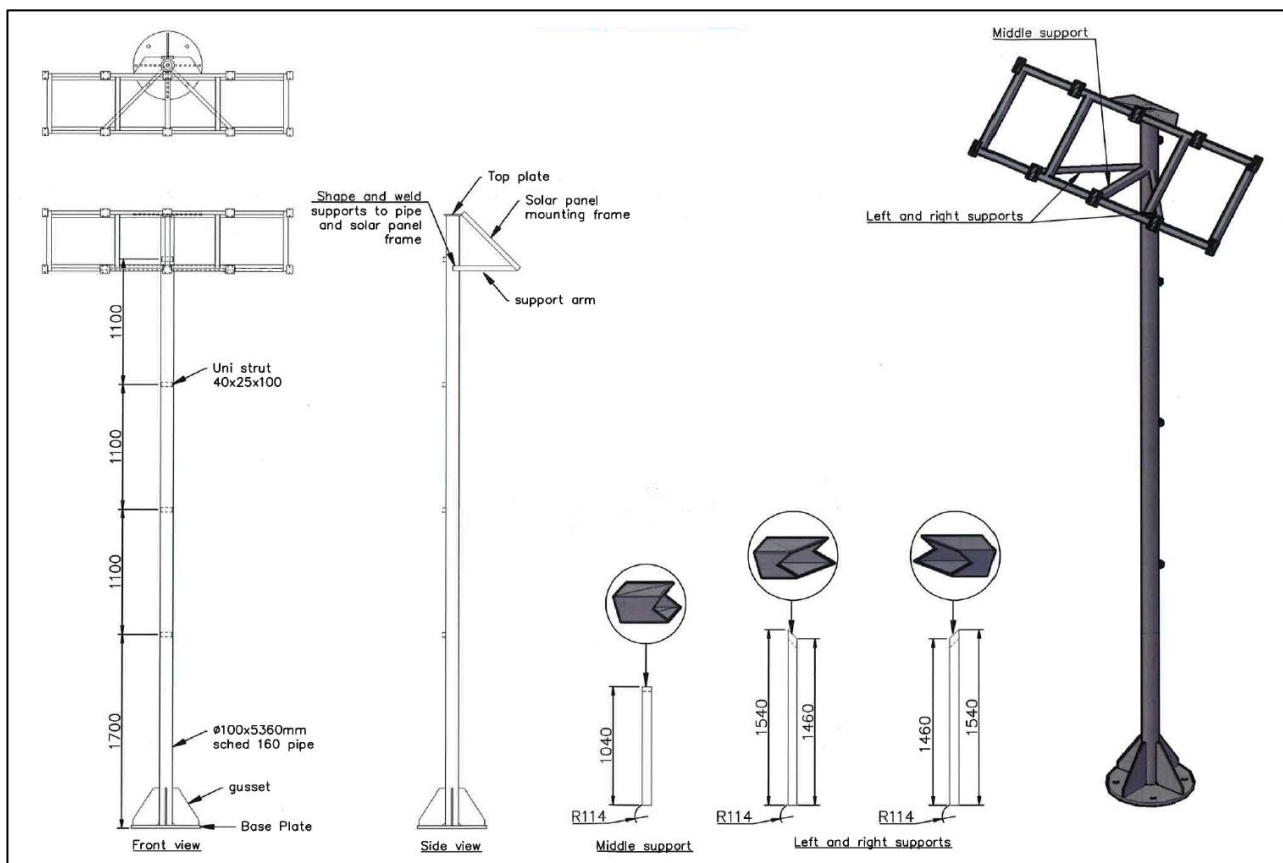

NB: Dimensions are typical, only.

## Appendix B - Site Schedules

### B1 Stand-alone Solar Power Supply System Site Schedule

SITE SCHEDULE			
Site Name			
Site Location Details			
<b>Cubicle Location</b> (Indoor/Outdoor)  (If indoors detail the location)			
Any Specific Installation Requirements			
LOAD DETAILS	Load Name	Load I (mA)	Duty (% of time)
12V DC			
Load 1			
Load 2			
Load 3			
Load 4			
Load 5			
24V DC			
Load 1			
Load 2			
Load 3			
Load 4			
Load 5			
240V AC			
Load 1			
Load 2			
Load 3			
Load 4			
Load 5			
SA WATER EQUIPMENT DETAILS			
Space Required in Control Cubicle	..... W    ..... H    ..... D    (mm)		
Pole (Tilt / Fixed)			
Antenna Support Required (Y/N)			



## B2 Example Schedule

SITE SCHEDULE			
Site Name	Belair North Tank		
Site Location Details	GPS Coordinates: 2222 222 222		
<b>Cubicle Location</b> (Indoor/Outdoor)  (If indoors detail the location)	Outdoors		
Any Specific Installation Requirements	None		
LOAD DETAILS	Load Name	Load I (mA)	Duty (% of time)
12V DC			
Load 1	SCADAPack RTU	720	100
Load 2	Radio APQQ-R400-SSC-HD-ENAA	3500	20
Load 3	Cabinet LED (3W)	125	Negligible
Load 4	Security	1500	100
Load 5			
24V DC			
Load 1	Ultrasonic Level Sensor	24	100
Load 2	Instrumentation Loops	40	100
Load 3			
Load 4			
Load 5			
240V AC			
Load 1			
Load 2			
Load 3			
Load 4			
Load 5			
SA WATER EQUIPMENT DETAILS			
Space Required in Control Cubicle	400 W    300 H    200 D    (mm)		
Pole (Tilt / Fixed)	Tilt		
Antenna Support Required (Y/N)	Yes		